



# Standard Test Method for Permeability of Thermoplastic Containers to Packaged Reagents or Proprietary Products<sup>1</sup>

This standard is issued under the fixed designation D2684/D2684M; the number immediately following the designation indicates the year of original adoption or, in the case of revision, the year of last revision. A number in parentheses indicates the year of last reappraisal. A superscript epsilon ( $\epsilon$ ) indicates an editorial change since the last revision or reappraisal.

## 1. Scope\*

1.1 This test method covers procedures for determining the permeability of thermoplastic containers to packaged reagents or proprietary products under specified conditions of exposure. The exposures used are intended to simulate the normal and elevated temperature-storage conditions that might be encountered in end-use application.

1.2 This test method is applicable only to those types of containers designed to allow positive, leakproof closure.

1.3 Two procedures are provided:

1.3.1 *Procedure A* is specific to testing only with a standard design container. This procedure provides for determinations of rate of weight loss (or gain) and for calculation of a permeability factor.

1.3.2 *Procedure B* applies to tests of all other container designs. Permeability data by this procedure are expressed only in terms of rate of weight loss (or gain) for the particular container tested.

1.4 *Units*—The values stated in either SI units or inch-pound units are to be regarded separately as standard. The values stated in each system may not be exact equivalents; therefore, each system shall be used independently of the other. Combining values from the two systems may result in non-conformance with the standard.

NOTE 1—There is no known ISO equivalent to this standard.

1.5 *This standard does not purport to address all of the safety concerns, if any, associated with its use. It is the responsibility of the user of this standard to establish appropriate safety and health practices and determine the applicability of regulatory limitations prior to use.*

<sup>1</sup> This test method is under the jurisdiction of ASTM Committee D20 on Plastics and is the direct responsibility of Subcommittee D20.19 on Film, Sheeting, and Molded Products.

Current edition approved Sept. 1, 2015. Published September 2015. Originally approved in 1968. Last previous edition approved in 2010 as D2684 - 10. DOI: 10.1520/D2684\_D2684M-15.

## 2. Referenced Documents

2.1 *ASTM Standards*:<sup>2</sup>

- D618 Practice for Conditioning Plastics for Testing
- D4976 Specification for Polyethylene Plastics Molding and Extrusion Materials
- D1505 Test Method for Density of Plastics by the Density-Gradient Technique
- E145 Specification for Gravity-Convection and Forced-Ventilation Ovens

## 3. Terminology

3.1 *Definitions*:

3.1.1 *permeability factor,  $P_t$* —the permeability of a given plastic to a given product at temperature  $t$ , in degrees Celsius, expressed in units of g·cm/day·m<sup>2</sup>, as determined by Procedure A. The permeability factor under 23°C test conditions, for example, is signified by the notation  $P_{23}$ .

3.1.1.1 *Discussion*—Determination of  $P_t$  is based on an averaged wall thickness over the entire area of the container and an assumption that permeation rate is inversely proportional to the thickness. Precaution in the extent of allowable variations of these factors is recommended, and the user of  $P_t$  needs to recognize that wall thickness of the containers varies, that the estimate of average thickness from density, area, and weight is not exact, and that permeability of the product through the plastic material is, generally, not directly proportional to the thickness.

## 4. Summary of Test Method

4.1 Test bottles are filled with the test product and, after sealing, are exposed at 23°C [73.4°F] and 50°C [122°F] conditions for 28 days or longer. Measurements of weight are made at intervals to determine the average rate of weight change.

<sup>2</sup> For referenced ASTM standards, visit the ASTM website, www.astm.org, or contact ASTM Customer Service at service@astm.org. For *Annual Book of ASTM Standards* volume information, refer to the standard's Document Summary page on the ASTM website.

\*A Summary of Changes section appears at the end of this standard

## 5. Significance and Use

5.1 With the proper precautions and background experience, results can be useful for estimation of the loss of a packaged product through the walls of a container during shelf storage. The test is also useful for isolating the effects of a container design and materials, and is applicable for development and research and for specification purposes.

5.2 In the absence of adequate supporting data, extrapolations or correlations of results to conditions beyond those of the test are not recommended because of possible product alteration, solvency, or chemical effects on the plastic, etc.

5.3 Before proceeding with this test method, refer to the specification of the material being tested. Any test specimen preparation, conditioning, dimensions, or testing parameters, or combination thereof, covered in the materials specification shall take precedence over those mentioned in this test method. If there are no material specifications, then the default conditions apply.

## 6. Apparatus

6.1 *Enclosure* or room with provision for maintaining the standard laboratory atmosphere of  $23 \pm 2^\circ\text{C}$  [ $73.4 \pm 3.6^\circ\text{F}$ ] and  $50 \pm 10\%$  relative humidity, as defined by Practice D618.

6.2 *Circulating-Air Oven*, consistent with ovens in accordance with Specification E145, capable of maintaining a temperature of  $50 \pm 1^\circ\text{C}$  [ $122 \pm 1.8^\circ\text{F}$ ] and an airflow rate of  $8.5$  to  $17.0\text{ m}^3/\text{min}$  [ $300$  to  $600\text{ ft}^3/\text{min}$ ]. The limitation of  $25\text{ ft}^3$  on oven size can be overlooked, provided all other requirements are met.

NOTE 2—The use of explosion-proof equipment with provision for adequate exhaust of vapors is recommended for tests with potentially hazardous or toxic products.

NOTE 3—Relative humidity variation can significantly affect permeability loss in many products, especially water-based products in various thermoplastics. For these purposes, it is recommended that the oven be equipped with a means to measure relative humidity and to record the same during the period of test.

6.3 *Balance*, accurate to  $0.01\%$  of the weight of test container and contents.

6.4 *Container Seals*, suitable heat-sealing laminate<sup>3</sup> and suitably lined screw-type closures for sealing the containers.

6.5 *Heat Sealer*.

6.6 *Torque Wrench*.

## 7. Reagents and Materials

7.1 The reagent or proprietary product as specified for testing.

## 8. Test Specimens

8.1 The test specimen for Procedure A shall be the 4-oz cylindrical bottle design as specified in Fig. 1, having a nominal external surface area of  $154\text{ cm}^2$  [ $23.8\text{ in.}^2$ ].

<sup>3</sup> One such laminate suitable for polyethylene containers, MIL-B-131C Class 2, a polyethylene-aluminum foil-paper laminate available from the Robertson Co., Jamaica, NY. Heat sensitive seals are also available from 3M Packaging Systems Division, 3M Center Building 220-8W-01, St. Paul, MN, 55144.

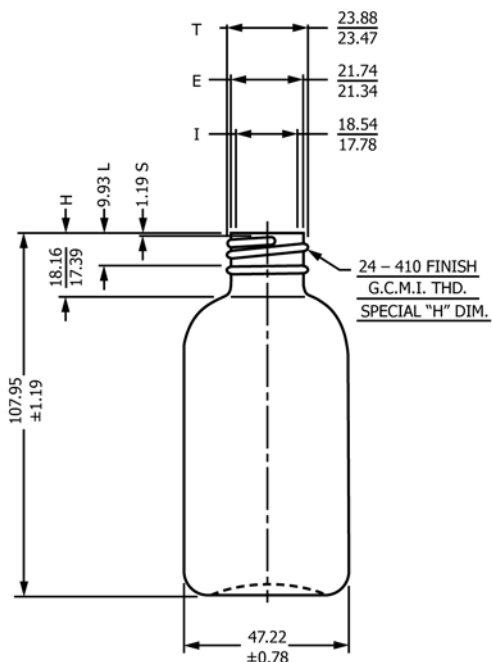

NOTE 1—Dimensions are in millimetres.

FIG. 1 Standard Container for Permeability Test

8.2 Any thermoplastic container, as specified or selected for test evaluation, can be used for Procedure B provided it is designed to allow positive closure.

8.3 For each procedure, a minimum of three specimens shall be tested at each temperature. Three additional specimens are required for Procedure A for determination of the plastic density.

8.4 If necessary, trim and finish the containers to ensure a smooth contacting surface for positive seal.

## 9. Conditioning

9.1 *Conditioning*—Condition the test specimens at  $23 \pm 2^\circ\text{C}$  [ $73.4 \pm 3.6^\circ\text{F}$ ] and  $50 \pm 10\%$  relative humidity for not less than 40 h prior to test in accordance with Procedure A of Practice D618, for those tests where conditioning is required. In cases of disagreement, the tolerances shall be  $\pm 1^\circ\text{C}$  [ $\pm 1.8^\circ\text{F}$ ] and  $\pm 5\%$  relative humidity.

9.2 *Test Conditions*—Conduct tests in the standard laboratory atmosphere of  $23 \pm 2^\circ\text{C}$  [ $73.4 \pm 3.6^\circ\text{F}$ ] and  $50 \pm 10\%$  relative humidity, unless otherwise specified in this test method. In cases of disagreements, the tolerances shall be  $\pm 1^\circ\text{C}$  [ $\pm 1.8^\circ\text{F}$ ] and  $\pm 5\%$  relative humidity.

## 10. Procedure A (Standard Container)

10.1 With specimens taken from the sidewalls of three of the containers, determine the average plastic density by Test Method D1505, or by an alternative method of equivalent accuracy.

10.2 For each test temperature, select a minimum of three containers. Weigh each when empty, without the closure and